

TECHNICAL DATA	<b>0</b>
	<b>1</b>
SAFETY INSTRUCTIONS AND WARNINGS	<b>2</b>
THREADED CONNECTIONS	<b>3</b>
SEALS AND BEARINGS	<b>4</b>
GENERAL OPERATIONS	<b>5</b>
PAINT TREATMENT	<b>6</b>
CONVERSION TABLES	<b>7</b>



## CONTENTS

	Page	Date
<b>1. VEHICLE MODELS</b> .....	1-1 ....	200325
1.1 Overview .....	1-1 ....	200325
<b>2. LOCKING COMPOUNDS AND SEALANTS</b> .....	2-1 ....	200325
2.1 General .....	2-1 ....	200325
<b>3. THREADED CONNECTIONS</b> .....	3-1 ....	200325
3.1 Tightening torques .....	3-1 ....	200325
<b>4. PAINT TREATMENT</b> .....	4-1 ....	200325
4.1 Overview of plastics used .....	4-1 ....	200325



## 1. VEHICLE MODELS

## 1.1 OVERVIEW

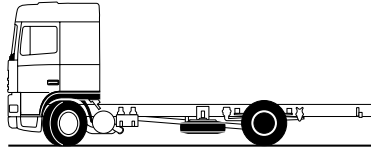
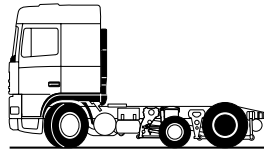
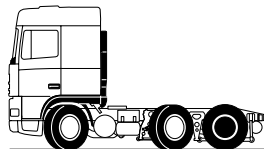
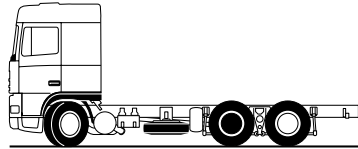
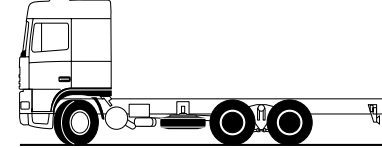
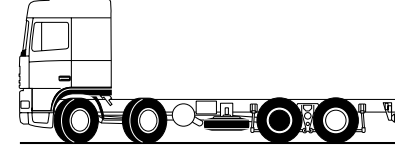
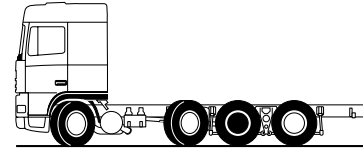
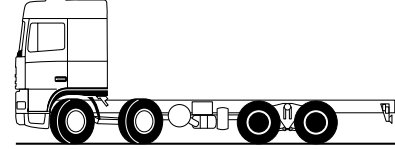
FT-FA	4 x 2	
FTP	6 x 2	
FTG	6 x 2	
FTS/R-FAS/R	6 x 2	
FTT-FAT	6 x 4	
FTC-FAC	8 x 2	
FAK	8 x 2	
FTD-FAD	8 x 4	

 steered axle

 driven axle

 trailing axle

GO 00 272



## 2. LOCKING COMPOUNDS AND SEALANTS

### 2.1 GENERAL



Certain cleaning agents have a negative effect on the functioning of locking compounds. The general rule is therefore that fasteners and components which have been cleaned with a cleaning agent must be treated with a cleaning liquid to ensure that the locking compound functions properly.

OVERVIEW OF LOCKING COMPOUNDS			
Product name	Properties	Applications	DAF number
Loctite 243	<ul style="list-style-type: none"> <li>- Locking with an average detaching strength</li> <li>- Detachable with normal tools</li> </ul>	Locking of threaded connections	0068197
Loctite 2701	<ul style="list-style-type: none"> <li>- Locking with a high detaching strength</li> <li>- Repairs the fit in bearing housings</li> <li>- Seals against leaks</li> <li>- Difficult to detach</li> </ul>	Locking of threaded connections, gear lever ball, freeze plugs	1340646
Loctite 638	<ul style="list-style-type: none"> <li>- Locking with a high detaching strength under dynamic load.</li> <li>- Difficult to detach</li> </ul>	Locking of cylindrical connections	0645557
Loctite 648	<ul style="list-style-type: none"> <li>- Locking with an average detaching strength</li> <li>- Resistant to high temperatures</li> </ul>	Locking of threaded connections in warm places	1357032
Loctite 262	<ul style="list-style-type: none"> <li>- Locking with a high detaching strength</li> <li>- Difficult to detach</li> </ul>	Locking of threaded connections, such as the pinion nut	1279841

**Applying the locking compound**

1. Clean both the internal and external thread.
2. Degrease the thread with a suitable degreasing agent which leaves no residue that could affect proper functioning.
3. Apply one or more drops of locking compound to the thread, depending on the diameter. Never dip the bolt or stud fully into the locking compound.
4. Apply a drop of oil under the bolt head. Locking compounds also reduce the frictional resistance, which means that applying a drop of oil to the thread is **not** required.
5. Tighten the connection to the specified torque.



OVERVIEW OF SEALANTS			
Product name	Properties	Applications	DAF number
Dirko D	<ul style="list-style-type: none"> <li>- Resistant to temperatures of up to 180°C</li> <li>- Resistant to oil, coolant</li> </ul>	Sealing of surface connections	1345014
Loctite 510	<ul style="list-style-type: none"> <li>- Resistant to temperatures of up to 200°C</li> <li>- Resistant to oil, brake fluid, coolant</li> </ul>	Sealing of surface (flange) connections that are subjected to high operating temperatures, such as the flywheel housing	0697149
Loctite 574	<ul style="list-style-type: none"> <li>- Resistant to high pressures (up to 350 bar)</li> <li>- Resistant to oil, brake fluid, coolant</li> </ul>	Sealing of surface connections against high pressures	1246867
Loctite Blue	<ul style="list-style-type: none"> <li>- Resistant to temperatures ranging from 60°C to 260°C</li> <li>- Resistant to oil</li> </ul>	Sealing of flexible constructions such as (valve) covers	1242895
Loctite ultra grey	<ul style="list-style-type: none"> <li>- Silicone sealant, good resistance to coolant</li> <li>- Resistant to temperatures of up to 325°C</li> </ul>	Sealing of (surface) connections in the cooling system	1284123
Loctite ultra copper	<ul style="list-style-type: none"> <li>- Silicone sealant, good resistance to oil</li> <li>- Resistant to temperatures of up to 350°C</li> </ul>	Sealing of surface connections such as hub covers	1284122
Loctite 5910	<ul style="list-style-type: none"> <li>- Silicone sealant, good resistance to oil</li> <li>- Resistant to temperatures of up to 200°C</li> </ul>	Sealing of surface connections, such as front and rear covers of gearboxes, differential housings, hub covers, shaft collars and oil cooler	1360102
Loctite 572	<ul style="list-style-type: none"> <li>- Seals against low pressure immediately after fitting</li> </ul>	Threaded connections	0292336
Loctite 5205	<ul style="list-style-type: none"> <li>- Surface sealant, specially designed for sealing aluminium parts</li> <li>- Resistant to temperatures of up to 150°C</li> <li>- Resistant to water, coolant and oil</li> </ul>	Sealing of aluminium parts	1441339
Loctite Form a gasket	<ul style="list-style-type: none"> <li>- Hardens on contact with metal and on full closure</li> </ul>	For locking, fastening and sealing	1322823

<b>OTHER PRODUCTS</b>			
<b>Product name</b>	<b>Properties</b>	<b>Applications</b>	<b>DAF number</b>
Tectyl	- Protects the cavities of the superstructure against corrosion	Post-treatment of cab parts to protect against corrosion. Can also be used to protect metal parts	1343888
Contact spray	- Cleaning agent for cleaning and degreasing electronic and electrical connections. Removes moisture and dirt from electrical contacts	Cleaning of electrical contacts	1387608
Loctite cleaner 7063	- Cleans and degreases - Non-inflammable and non-corrosive	For cleaning/de-greasing materials to which a locking compound must be applied	1322827
Molykote BR 2 PLUS	- Lubricating grease is heat-resistant from -30°C to +130°C	Everywhere where grease lubrication is appropriate and normal - For almost all ball and roller bearings, plain bearings, guides, couplings, splined shafts, threaded spindles, sprocket drives with a low speed	1389512
Molykote P37	- Lubricating grease protects against corrosion and is heat-resistant up to 1400°C.	For threaded connections that are exposed to high temperatures, as used for exhaust systems	1391619
Copaslip	- Copper paste with an excellent bond, is anti-corrosive and heat-resistant from -35°C to 1100°C. - Resistant to water, salts and acids. - Prevents wear, oxidation, rust, corroding and locking of metal surfaces.	For connections that are vulnerable to oxidation or corrosion, such as battery terminals, exhaust couplings etc.	1284344
Renolit HLT2	- Lubricating grease (white)	Disc brake adjustment device	1448907
Syntheso-GL EP1	- Lubricating grease (green)	Rubber guides, disc brake	1448908
Gleitmo 805	- Protects untreated metals against corrosion	For parts which are attached with a fit such as wheel hub units	1443160

### 3. THREADED CONNECTIONS

#### 3.1 TIGHTENING TORQUES

0

#### TABLE OF STANDARD TIGHTENING TORQUES, STANDARD 00804-203

The tightening torques in the table below are standard torques and only apply to dipped threaded connections.

The property codes are stamped on the nut and bolt, except on the clamping flange bolt. The clamping flange bolt is recognised by a constriction between the hexagonal bolt head and the flange. This constriction is absent in standard flange bolts.

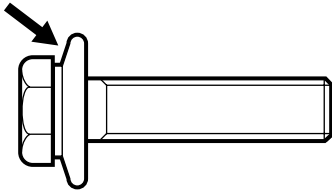

Clamping flange bolt

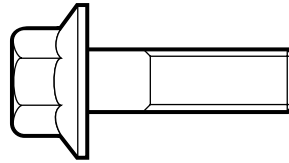

Standard flange bolt

M2 00 001

## TIGHTENING TORQUES FOR DIPPED THREADED CONNECTIONS

Overview of standard tightening torques for DAF flange bolts and nuts, strength class 10.9/10.

Thread pitch	Tightening torque (Nm)	Extra angular displacement ( $\pm 10\%$ ) for bolt stem length L (mm):			
		L $\leq$ 40	41-80	81-130	131-180
M8	30 $\pm$ 2	30°	60°	90°	120°
M10	60 $\pm$ 4	45°	90°	120°	150°
M12 x 1.75	110 $\pm$ 8	30°	60°	90°	120°
M12 x 1.25	110 $\pm$ 8	45°	90°	120°	150°
M14 x 2	170 $\pm$ 15	30°	60°	90°	120°
M14 x 1.5	170 $\pm$ 15	45°	90°	120°	150°
M14 x 2	for brake back plates: 170 $\pm$ 15 Nm +60°				
M16 x 2	260 $\pm$ 20	30°	60°	90°	120°
M16 x 1.5	260 $\pm$ 20	45°	90°	120°	150°
M18 x 2.5	360 $\pm$ 30	30°	45°	60°	80°
M18 x 1.5	360 $\pm$ 30	45°	90°	120°	150°
M20 x 1.5	520 $\pm$ 40	45°	90°	120°	150°
M22 x 2.5	for steering and track rod arms: 500 $\pm$ 50 Nm +90°				

The bolt stem length L is the length of the bolt between the bolt head and the nut.

If a component is attached with several bolts, all bolts must first be tightened to the specified torque, and subsequently by the angular displacement.

**Overview of standard tightening torques for  
DAF fastenings, strength class 8.8/8**

Thread	Tightening torque in Nm
M4	2,8 ± 0,2
M5	5,5 ± 0,4
M6	9,6 ± 0,7
M8	23 ± 2
M10	46 ± 4
M12	79 ± 6
M14	125 ± 9
M16	195 ± 14
M18	280 ± 20
M20	395 ± 30
M22	540 ± 40
M24	680 ± 50
M27	1000 ± 70
M30	1350 ± 100

**Overview of standard tightening torques for  
DAF flange bolts and nuts, strength class  
12.9/12.**

Thread	Tightening torque in Nm
M8	32 ± 3
M10	67 ± 5
M12	113 ± 9
M14	178 ± 14
M16	274 ± 22
M18	385 ± 30
M20	550 ± 43
M22	740 ± 60
M24	925 ± 72
M27	1370 ± 110

### Overview of standard tightening torques for DAF clamping flange bolts and nuts, strength class 12.9/12

Thread	Tightening torque in Nm
M12	178 ± 14
M14	274 ± 22
M16	425 ± 35
M18	550 ± 45

### Overview of tightening torques, banjo bolts

Thread	Tightening torque in Nm
M6	8 ± 0,8
M8	15 ± 1,5
M10	30 ± 3
M12	40 ± 4
M14	50 ± 5
M16	60 ± 6
M18	70 ± 7

#### Torque wrench

- Have torque wrenches regularly inspected and calibrated.

#### Re-use of fasteners (bolt/nut/threaded end)

1. Clean the thread (take particular care to remove locking compound residues) and the clamping faces.
2. Check the thread for damage.  
Screw a new nut/bolt onto the thread by hand to check it.  
If the new nut/bolt cannot be screwed down over the whole thread of the fastener to be checked, the fastener must not be reused.

3. Apply one drop of engine oil to the first turn of the bolt/(threaded end)/lower turn of the nut and one drop to the clamping faces (other lubricants are not allowed).
4. If a locking compound was specified, no oil should be applied to the thread.

**New bolts/nuts**

New DAF bolts and DAF nuts, except bolts M4 to M8 with inner-Torx, are all treated with a lubricant.

If bolts have not been treated with a lubricant, this should be done as yet.

1. Apply one drop of engine oil to the first turn of the bolt/lower screw thread of the nut and one drop to the clamping faces (other lubricants are not allowed).
2. If a locking compound was specified, no oil should be applied to the thread.





## 4. PAINT TREATMENT

## 4.1 OVERVIEW OF PLASTICS USED

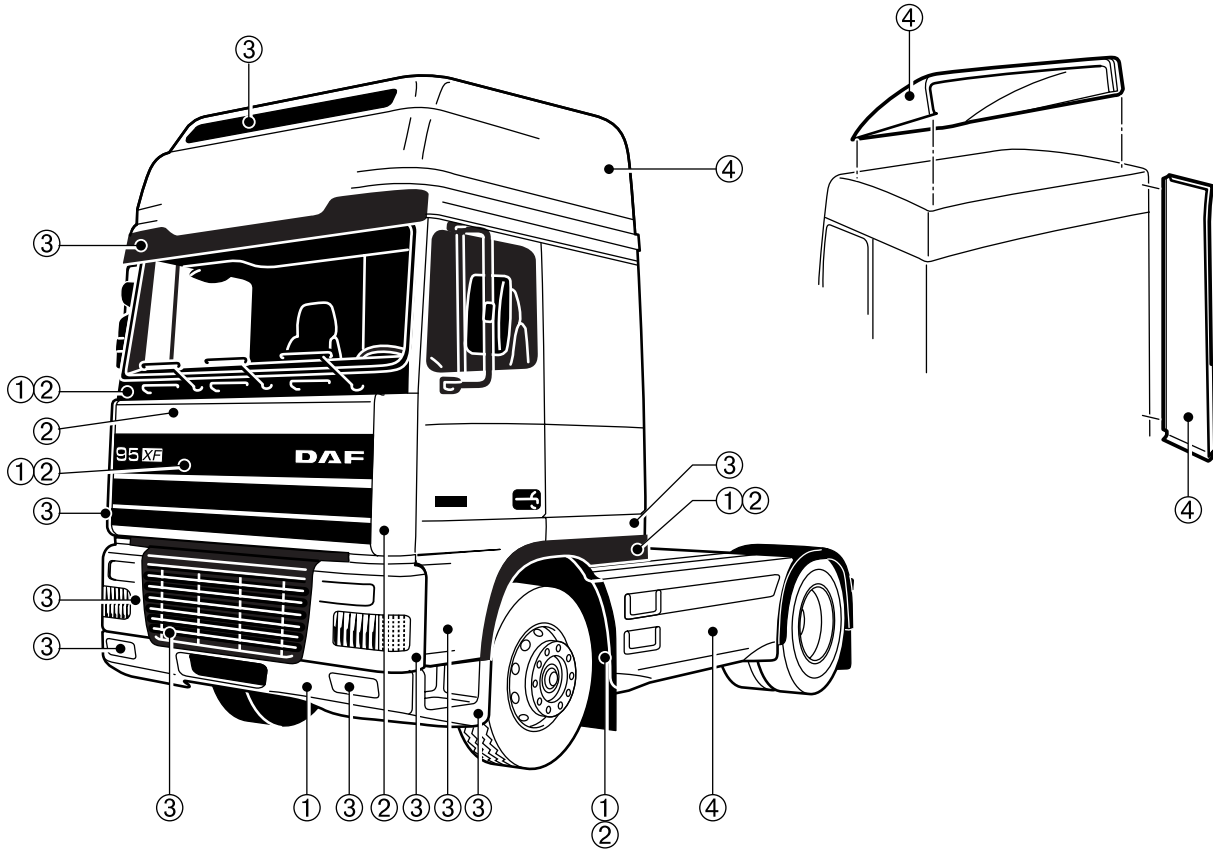

K100358

1. Seed top coats
2. SMC polyester parts
3. Thermoplastic polymer parts
4. SMC fibre-glass reinforced polyester parts



## CONTENTS

	Page	Date
1. SAFETY SPECIFICATIONS .....	1-1 .....	0107
2. WARNINGS .....	2-1 .....	0107
2.1 Batteries .....	2-1 .....	0107
2.2 Welding .....	2-3 .....	0107
2.3 Jump-starting .....	2-5 .....	0107
2.4 Plastic pipes .....	2-6 .....	0107
2.5 Wiring harnesses .....	2-9 .....	0107
2.6 Avoiding the risk of fire .....	2-10 .....	0107
2.7 Tachograph calibration .....	2-11 .....	0107



## 1. SAFETY SPECIFICATIONS

### WARNING SYMBOL

When text is accompanied by the warning symbol shown here, this indicates that the information provided is essential for the health and personal safety of the mechanic. This warning symbol is also shown if circumstances threaten the safety of the vehicle or could lead to damage to the vehicle.

### SAFETY PRECAUTIONS

To ensure that the mechanic's health is not endangered, the following safety instructions must be strictly observed.

- Comply with all the warnings and safety instructions given in this workshop manual. First read the instructions and warnings on the labels and stickers which are affixed to the various components and comply with them! They have been put there for your health and safety, so do not ignore them!
- Wear clean, well-fitting clothes and apply protective cream to unprotected parts of your body, if necessary.
- Always disconnect the earth lead of the battery before working on the vehicle.
- Do not run the engine in an enclosed or unventilated area. Make sure exhaust fumes are properly extracted.



M0015

- Remain at a safe distance from rotating and/or moving components.
- Do not remove the filler cap of the cooling system when the engine is at operating temperature.
- Be careful when changing the oil. Hot oil can cause serious injuries.
- Avoid unnecessary contact with drained oil. Frequent contact damages the skin.
- Various sorts of oil and other lubricants used on the vehicle may constitute a health hazard. This also applies to engine coolant, windscreen washer fluid, refrigerant in air-conditioning systems, battery acid and diesel fuel. So avoid inhaling and direct contact.
- Tilt the cab fully if work must be carried out underneath the cab.
- Always use stands to support the chassis or components when working under the vehicle.
- Be careful when working on activated springs, such as those in spring-brake cylinders, valves, and similar. Inadvertently released springs may cause serious injuries. Small springs and circlips may also cause injuries when inadvertently released (wear goggles).
- Always use a tyre cage when fitting and inflating tyres. Thoroughly clean tyres prior to balancing. Only use a balancing device fitted with a protective cover.

- Always use the appropriate lifting gear (gearbox jack) or approved hoists for the removal and installation of heavy components. Attach the component securely to the lifting or hoisting gear.
- Be careful when working on systems which may be under pressure, such as a trailing axle lifting device, cab tilting mechanism, brake system, steering gear, fuel system, etc.
- Always charge batteries in a properly ventilated area and avoid sparking and naked flames. Always switch the battery charger off before removing the leads. Fast-charging should only be resorted to in an emergency. Disconnect the battery leads when fast-charging is being used.
- After a fire it is possible that hazardous residues may remain from the plastics used in some oil seals and sealing rings. Wear protective, acid-resistant clothing and PVC gloves when removing such fire residues. Submerge such fire residues in, or sprinkle them amply with, a calcium hydroxide solution (slaked lime and water). Thoroughly clean the protective clothing after use. Treat the gloves as chemical waste.





## 2. WARNINGS

### 2.1 BATTERIES



**Non-compliance with the warnings contained in this section may result in serious damage to the vehicle and may even lead to dangerous situations.**



**Battery acid is a corrosive fluid. In the event of contact with the skin: Rinse the skin with plenty of water for a sustained period. If redness or pain persists, consult a doctor. Remove any clothing affected and rinse with water. In the event of contact with the eyes: Rinse with plenty of water for at least 15 minutes and see a doctor. If any is swallowed: do NOT induce vomiting. Rinse the mouth, drink two glasses of water and see a doctor. In the event of inhalation: get some fresh air, rest and consult a doctor.**

To prevent damage to electronic components, never disconnect the battery terminals when the engine is running.

Always disconnect the earth lead of the battery before working on the vehicle. Never place tools on a battery. If you do, this could short-circuit the battery or even cause the battery to explode.

#### Charging

- Always charge batteries in a properly ventilated area and avoid sparking and naked flames. When charging batteries, an explosive gas mixture may be released.
  - Fast-charging should only be resorted to in an emergency.
1. Thaw out frozen batteries before charging them.
  2. Remove all the filler caps before charging, so that any gases released can escape to the atmosphere.

3. When fast-charging, the battery positive and negative leads (+ and -) must be disconnected to prevent damage to electronic components.  
During "normal" charging, the battery leads may remain connected.
4. First connect the positive lead (+) of the battery charger to the positive terminal (+) of the battery and then the negative lead (-) to the negative terminal (-).
5. Before disconnecting the battery charger leads, first switch off the battery charger to avoid sparking and to eliminate the risk of explosion.
6. To disconnect, first release the negative terminal (-) and then the positive terminal (+).

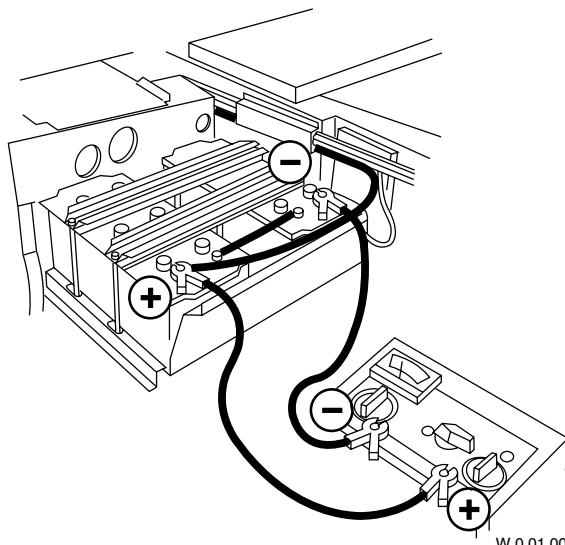

## 2.2 WELDING



**No welding of the chassis is allowed without special, written permission by DAF. Exceptions to the above are the welding operations described in the manual "Superstructure directives". Non-compliance with welding regulations may cause serious damage to the chassis.**



**Failure to observe the following instructions may damage the electronic components.**

### General

- Attach the earth clamp of the welding set as close as possible to the area on the vehicle where the welding is to be done and ensure that it is well in contact with the part being welded.
- Never attach the earth clamp to vehicle components such as the engine, axles, springs, etc. Arcing on these components is also not permitted. Non-compliance with the above instructions may result in serious damage to bearings, springs, etc.
- The accessory or contact position of the ignition lock must not be switched on. Remove the ignition key from the ignition lock.
- Protect plastic piping, rubber components, plastic components, piston rods of hydraulic cylinders and springs (in particular parabolic springs) from welding splashes and temperatures above 70°C.

### **Welding to the chassis**

- When welding on the chassis, disconnect the connectors of all electronic equipment (including sensors and actuators), if they are within a 1-metre radius of the point being welded or within a 1-metre radius of the earthing point.
- Disconnect the battery terminals if these are within a within a 1-metre radius of the point being welded or the earth terminal.
- If the battery terminals have to be disconnected, all electronic units mounted on the chassis must be disconnected as well. Also detach the cab feed-through connectors.

### **Welding on the cab**

- When welding on the cab, disconnect the battery terminals.
- Disconnect the cab feed-through connectors.
- Disconnect the connectors of all electronic equipment (including sensors and actuators), if they are within a 0.5-metre radius of the point being welded or within a 0.5-metre radius of the earth terminal.

### **Welding on the superstructure**

- Follow the instructions for "Welding on the chassis", together with any specific welding instructions for welding on the superstructure.

### **Note:**

During grinding, protect plastic piping, rubber components, plastic components, piston rods of hydraulic cylinders and springs (in particular parabolic springs) in order to prevent damage caused by grinding sparks.

**Position of cab feed-through connectors**

The cab feed-through connectors are located at the cab front.

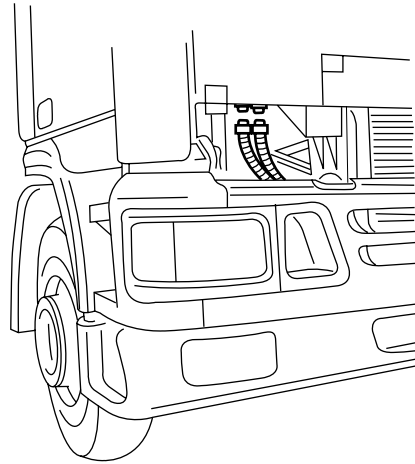

W 0 01 003

**2.3 JUMP-STARTING**

- **Never start the vehicle by means of a fast-charging device.**
- **The engine may be started with the aid of jump leads using the power from separate auxiliary batteries (approx. 24V) or from another vehicle with the engine running (approx. 28V).**

1. Connect the jump leads first to the positive terminal (+), and then to the negative terminal (-).
2. Start the engine.
3. After starting, switch on as many power consumers as possible on the assisted vehicle, in order to avoid a so-called load dump.
4. Then disconnect the jump leads from the negative terminal (-) first, followed by the positive terminal (+).
5. Switch the power consumers off again.

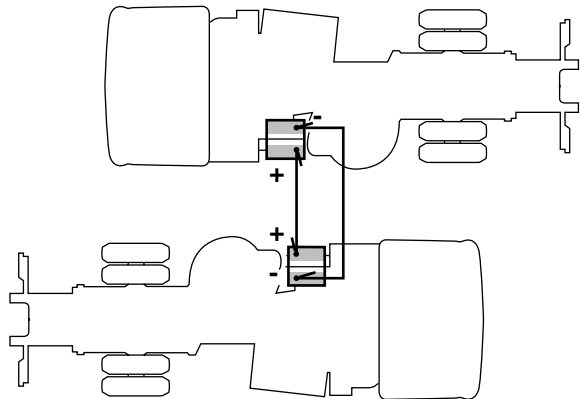

W 0 01 004

## 2.4 PLASTIC PIPES

### Removing nipples or banjo unions in polyamide pipes

1. Heat the pipe to remove the nipple or banjo union. Never remove the nipple or banjo union by making an incision in the longitudinal direction of the pipe. This could easily result in damage of the hose adapter. Even minor damage to the hose adapter will cause leakage.

### Fitting nipples or banjo unions in polyamide pipes

1. Do not fit nipples or banjo unions to the same pipe end more than once, because this could result in poor sealing.
2. Cut off the pipe end if it has been used before. If shortening the pipe results in a sharp curve in the pipe or if it makes the pipe too short, a new pipe will have to be fitted.
3. Always use a special spanner (Special Tools, DAF No. 0694829) to fit nipples and banjo unions in polyamide pipes.
4. Clamp the plastic pipe in the special pliers (1).
5. Use a plastic mallet to tap the nipple or banjo union into the pipe.

#### Note:

Never heat a plastic pipe when fitting nipples or banjo unions.

#### Leakage from pipes

Leakage from fuel and air pipes must be remedied as soon as possible to avoid dangerous situations.

A leaking fuel pipe may constitute a fire hazard, while a leaking air pipe may affect the braking performance of the vehicle.

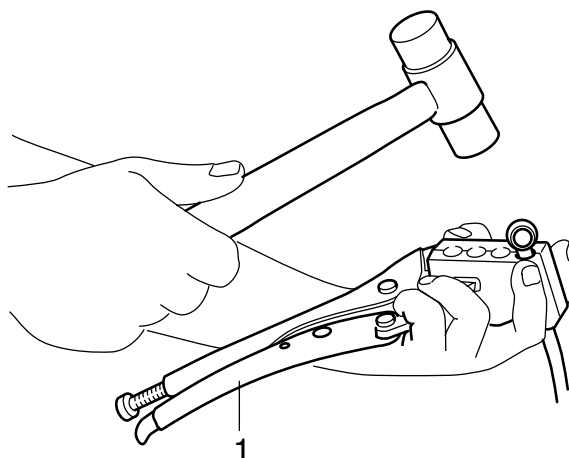

W 0 01 005

In the event of a leakage from a pipe coupling, unlimited tightening of the union nut or banjo bolt is not permitted.

- First check whether the leak is at the connection point between the pipe and coupling or at the connection point between coupling and the component housing.
- Tighten a banjo bolt to the tightening torque specified for the banjo bolt in question.
- A union nut may be tightened a further half turn (180°) only once. Tightening the union nut further than this is possible, but entails the risk of excessive deformation of the thrust washer and the pipe, which would seriously weaken the pipe.
- If the leakage has not stopped after the union nut has been retightened, it will be necessary to take the coupling apart.
- Check the parts for deposits and/or damage. Even a small longitudinal scratch on the pipe connector of a nipple or a banjo union may be sufficient to cause a leak.
- In the case of a banjo bolt fastening, check the sealing surfaces. Fit new sealing rings to the fastening and fit them. Tighten the attachment bolts to the specified torque. See "Technical Data".

#### **Chafing of pipes**

When plastic pipes touch each other or other parts of the vehicle, they may get chafed.

Immediately replace any pipes that show signs of wear.

When pipes are fitted so close together or so close to other parts of the vehicle that they may touch, they should be secured to prevent chafing.

Releasing an elbow or T-piece and then tightening it in a slightly different position can sometimes prevent chafing.

Secure the pipes with cable ties.

2

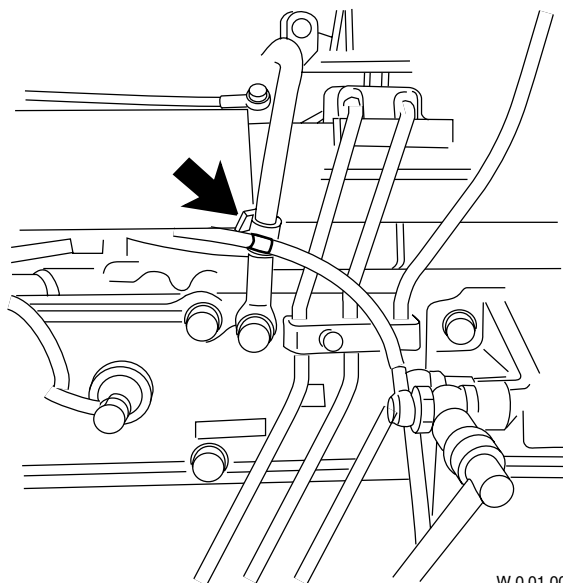

W 0 01 006

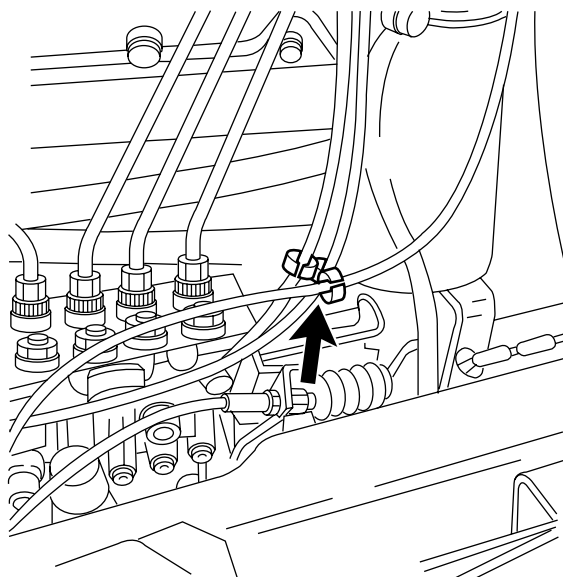

W 0 01 007



## 2.5 WIRING HARNESSES

After the first wiring harness has been disconnected or replaced, it must be reconnected in the original manner and fastened.

Protect the wiring harness against contact with sharp edges. Always use a grommet when passing the wiring harness through an aperture.

Protect the wiring harness by enclosing it in a protective sleeve.

Make sure that the joints are watertight. Never remove sealing rings from connectors. Fit the connectors in the correct manner.

Good earth connections are essential. There must be no paint or oxidation between the contact surfaces. Before assembly, apply a conductive grease such as "Coranode" or a similar product to the contact surfaces. Tighten the attachment bolt securely.

Make sure that wiring is not located too close to parts which become hot during operation.

Freely suspended cables, such as those between the chassis and the cab, must not be kinked or pinched between other parts.

Prevent wiring harnesses from scraping against plastic pipes.

The pins of connectors must always be installed and removed with special tools, to prevent poor connections.

## 2.6 AVOIDING THE RISK OF FIRE

- Check fuel pipes for leakage and fix any leakage immediately. (see also Plastic pipes).
- When fitting steel fuel pipes take into account the points listed below.  
Fit the fuel pipe free from tension.  
Preformed fuel pipes must not be bent.  
When refitting a banjo bolt on a fuel pipe, always fit new sealing rings and tighten the banjo bolt to the specified torque.  
After tightening, check the fastening for fuel leakage.  
Steel fuel pipes fitted without due care and attention can cause fuel leaks which lead to fire hazard.
- In the event of fuel and/or oil leakage or spillage, the engine encapsulation must be thoroughly cleaned. First apply a degreasing agent to the encapsulation material. Then wash down the encapsulation with a steam cleaner or with a high-pressure cleaner.



**Maintain a minimum distance of 50 cm between the engine encapsulation and the sprayer nozzle to prevent damage to the encapsulation.**

- Clean the engine compartment, and in particular the encapsulated part, at regular intervals, by removing flammable material such as dead leaves and sawdust.
- Do not leave cleaning rags or other such things in the engine compartment.
- Repair leaks in the exhaust system without delay. Badly corroded exhaust components should be replaced before they fail.

- Always remember to re-fit the heat shields after removal.
- Never replace a defective fuse by a fuse of a higher rating.
- Never connect accessories which are not protected by a fuse.
- Check wiring which is not fuse-protected (battery leads, etc.), to make sure that it is undamaged and properly attached and located.

## 2.7 TACHOGRAPH CALIBRATION

The test bench may be used to calibrate the tachograph (e.g. when changing to a different type of tyre).

If the vehicle is equipped with ASR, the system will interpret turning rear wheels and still front wheels as rear wheel spin. As deceleration is no longer applicable, the system will try to neutralise this "spinning" by slowing down the rear wheels. The result is that the vehicle is thrown from the test bench, which is dangerous.

In order to avoid this, the ABS/ASR system fuses must be removed, rendering the ABS/ASR system inactive.

However, this is viewed by the system as faults to be registered in the memory. These faults must be reset after calibration using DAVIE.



CONTENTS

	Page	Date
1. GENERAL .....	1-1 .....	0107
1.1 Dipped threaded connections .....	1-1 .....	0107



## 1. GENERAL

### 1.1 DIPPED THREADED CONNECTIONS

DAF vehicles are fitted with threaded connections which have been treated with a lubricant (dipped threaded connection). Factory-galvanised bolts and nuts are wax-dipped. Black annealed and phosphatised bolts and nuts are oil-dipped. The advantage of using a lubricant is that friction during tightening of the threaded connection is reduced, so that the specified pre-tension can be obtained more easily and more accurately. The tightening torque can be reduced while the pre-tension force remains the same.

To achieve a small spread in the pre-tension force, the dipped threaded connection must be tightened accurately. Therefore, always use a reliable and accurate torque wrench.

**Note:**

Have torque wrenches regularly inspected and calibrated.

To achieve the correct pre-tension when re-using threaded connections, it is important to clean the threaded parts thoroughly. After cleaning, apply one drop of lubricant to the first turn of the screw thread and one drop to the abutting surface of the nut or bolt. Only use engine oil as a lubricant for re-used bolts and nuts. Lubricants other than engine oil or factory-applied grease must not be used in any circumstances because of the difference in frictional coefficient.

When locking compounds are used for dipped threaded connections, the instructions given here apply, except for applying lubricant to the first turn of the screw thread.

**The following applies to all threaded connections (for both new and used vehicles):**

- in the case of standard connections, apply the lubricant before fitting, and tighten/retorque in accordance with the standard for dipped bolts;
- in the case of special connections, apply the lubricant before fitting, and tighten/retorque in accordance with the values specified in the instructions.

**3**

The instructions for using a lubricant also apply to new bolts supplied from the warehouse. Dry threaded connections are not permitted because of their highly variable friction coefficients.

The following threaded connections are used on DAF vehicles:

- Fastenings with strength class 8.8 and 8,
- flange bolts and nuts with strength class 10.9 and 10,
- flange bolts and nuts with strength class 12.9 and 12,
- clamping flange bolts and nuts with strength class 12.9 and 12.

### **Threaded connection 10.9/10**

A threaded connection 10.9/10 is tightened as standard with a torque followed by an angular displacement. The angular displacement depends on the bolt stem length. For the tightening torque with the applicable angular displacement, see "Technical Data".

If a threaded connection 10.9/10 has to be tightened differently, for example using a tightening torque only, this is indicated in the technical data for the component concerned.



**Other threaded connections**

Threaded connections 8.8/8, 12.9/12 and clamping flange bolt 12.9/12 are tightened as standard only with a torque. For the standard tightening torques, see the "Technical Data". If any of these threaded connections has to be tightened differently, this is indicated in the technical data for the component concerned.

**Application, locking compound**

1. Clean both the internal and external thread.
2. De-grease the thread with a suitable de-greasing agent which leaves no residue that could affect proper functioning.
3. Apply one or more drops of locking compound to the thread, depending on the diameter. Never dip the bolt or stud into the locking compound.
4. Apply a drop of oil under the bolt head. Locking compounds also reduce the frictional resistance, which means that applying a drop of oil to the thread is **not required**.
5. Tighten the connection to the specified torque.



**CONTENTS**

	<b>Page</b>	<b>Date</b>
<b>1. GASKETS</b> .....	1-1 .....	0107
1.1 Paper and Klingerit gaskets (rubber-aramide fibre) .....	1-1 .....	0107
1.2 Liquid gaskets .....	1-2 .....	0107
<b>2. SEALS</b> .....	2-1 .....	0107
2.1 Removing and fitting sealing rings .....	2-1 .....	0107
<b>3. BEARINGS</b> .....	3-1 .....	0107
3.1 Bearings, general .....	3-1 .....	0107
3.2 Fitting bearings into a bearing housing .....	3-2 .....	0107
3.3 Fitting bearings to a shaft .....	3-2 .....	0107



## 1. GASKETS

### 1.1 PAPER AND KLINGERIT GASKETS (rubber-aramide fibre)

The workshop manual specifies when a gasket is required and it also gives information about the type of gasket to be used.

1. Remove the old gasket before fitting a new one.
2. Clean the contact surfaces and check them for damage.
3. Paper gaskets should be sparingly greased before they are fitted. These gaskets are used to seal flat parts and are resistant to oil and moderate heat.
4. Do not grease Klingerit gaskets before fitting. These gaskets are usually graphitised. They are used to seal flat surfaces and are resistant to oil, water and heat.
5. There are special instructions for cylinder head gaskets. See the relevant section.
6. Always tighten the attachment bolts evenly.

### 1.2 LIQUID GASKETS

The workshop manual specifies when a gasket is required and it also gives information about the type of gasket to be used.

Liquid gaskets, which replace conventional gaskets, have been developed to seal flat connections. They are resistant to oil, water and temperatures up to approx. 200°C.

To apply a liquid gasket, follow the instructions below.

#### **Application, liquid gasket**

1. Remove all traces of the old gasket and clean the surfaces to be sealed.
2. Sparingly apply the specified sealant to one of the surfaces to be sealed. Also apply sealant around studs, bores and the like to ensure they are properly sealed.
3. If sealant has got into an oil bore (or other), remove it carefully.
4. Put the surfaces to be sealed against each other and tighten the attachment bolts evenly.

## 2. SEALS

### 2.1 REMOVING AND FITTING SEALING RINGS

There are two different kinds of sealing rings: conventional sealing rings and unitised sealing rings.

- The conventional sealing ring is fitted in a recess and its inner ring has its running surface on a shaft.
- The unitised sealing ring is fitted in a fixed position both in a recess and on the shaft. Sealing is achieved internally.

#### Removing a sealing ring

1. If possible, remove the sealing ring with the special tool (DAF no. 1329458 or DAF no. 0694928 (A) and 0484899 (B)). When removing the sealing ring, take care not to damage the recess.

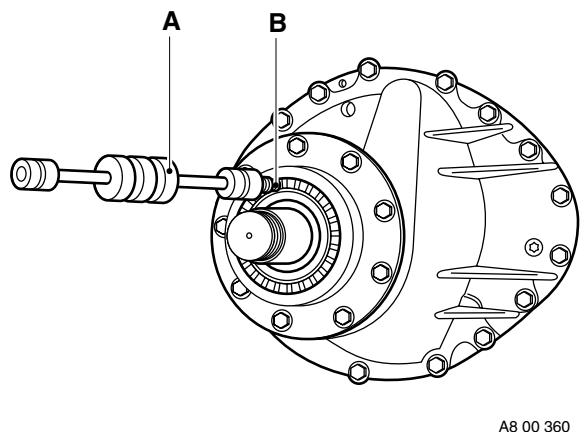
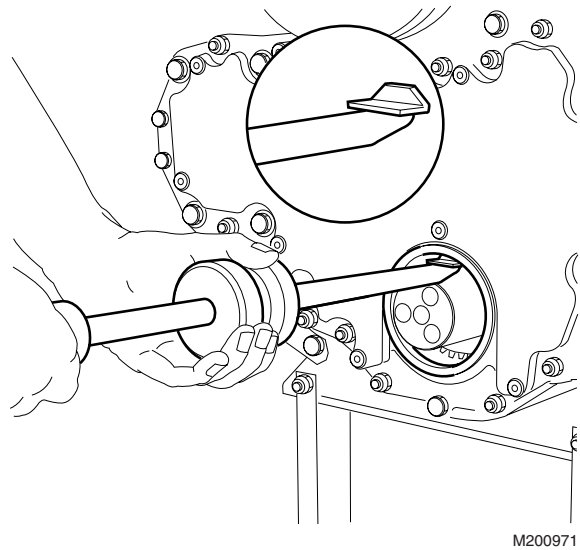

### Installation, seal

1. Check the recess in which the sealing ring is to be fitted for damage. Make good any damage.
2. Look for any marks on the outside of the sealing ring indicating the direction of rotation of the shaft.
3. Always use a suitable driving tool to fit a sealing ring and press the ring evenly to its place in the recess.
4. Once a unitised sealing ring has been removed from the recess, it must not be re-used.
5. In most cases, a liquid gasket is used to fit a conventional sealing ring with a steel sheathing, whereas oil or liquid soap is used to fit a sealing ring with a rubber sheathing.
6. Always fit unitised sealing rings dry, unless stated otherwise.
7. Always apply a little amount of oil or grease to the sealing lip(s) and running surface of a conventional sealing ring.



### 3. BEARINGS

#### 3.1 BEARINGS, GENERAL

1. Bearings must be replaced if they are worn, in the case of pitting (small dents in the running surface) and/or if the bearings have been exposed to excess heat (blue spots).
2. When fitting a bearing, make sure that no force is transmitted via the balls or rollers of the bearing. For example, by fitting a bearing on a shaft by pressing on the outer bearing race.
3. Clean the bearing before fitting it.
4. Avoid dirt getting into the bearing while it is being fitted.
5. If the instructions specify that the bearing should be heated before it is fitted, avoid exceeding the temperature specified. Also avoid local overheating.
6. Raise the temperature of the bearing evenly by heating it in the special oil bath. Another option is to place the bearing on an electric cooker. Watch the temperature closely in this case.

## 3.2 FITTING BEARINGS INTO A BEARING HOUSING

Fitting bearings into a bearing housing

1. Always use the correct size of driving tool.
2. Centre the driving tool accurately on the outer bearing race.
3. Preferably press the bearing evenly into the housing, using a pressing tool.

## 3.3 FITTING BEARINGS TO A SHAFT

Fitting bearings to a shaft

1. Always use the correct size of driving tool.
2. Centre the driving tool carefully on the inner bearing race.
3. Preferably press the bearing evenly onto the shaft, using a pressing tool.

CONTENTS

	Page	Date
1. <b>PRESERVATION AND DEWAXING</b> .....	1-1 .....	0107
1.1 Preservation .....	1-1 .....	0107
1.2 Dewaxing .....	1-2 .....	0107
2. <b>CLEANING VEHICLES</b> .....	2-1 .....	0107
2.1 Highpressure cleaner .....	2-1 .....	0107



## 1. PRESERVATION AND DEWAXING

### 1.1 PRESERVATION

**Note:**

Observe the applicable environmental requirements.

1. Clean the vehicle thoroughly so that all dirt and dust are removed.
2. Use pressurised air to remove any residues from the vehicle.
3. Cover all glazing, headlights and tail lights.
4. Use a spray gun to spray undiluted preserving agent RUSAN D5018 (a FINA product) over the chassis frame and its fittings, all parts and components in the engine compartment and all painted sheet metal parts. Tilt the cab to be able to spray the preserving wax on the cab roof. Make sure that all edges, joints and cavities are sprayed with a full jet of preserving wax.
5. Use a brush to apply Rusan D5018 to the wheel studs.



**On no account spray preserving agent into brake drums or on to brake discs.**



**Spending the night in a preserved cab is not allowed. Sleeping in preserved cab may cause nausea and headaches.**

## 1.2 DEWAXING

**Note:**

Observe the applicable environmental and safety requirements.

The vehicle should preferably be placed on a grid floor.



**Most dewaxing agents are inflammable. The dewaxing area should be suitable for the safe use of such products.**

1. Remove the preserving agent with a solvent, an emulsifying cleaner or a highpressure hot water cleaner with added solvent.

Dewaxing with a highpressure hot water cleaner should be done carefully and evenly. Set the highpressure hot water cleaner to a maximum pressure of 100 bar and a maximum temperature of 90°C. Never direct the jet of wax remover too long at the same area, for this could cause serious damage to the paintwork and rubber. If some parts of the treated surface still have preserving agent on them, treat these areas again in the same way.

**Note:**

A steam cleaner is not suitable for dewaxing because it requires the use of calcium descaling products to keep the inside of the steam coil clean. The dried residues of these products are difficult to remove.

2. After removing the dewaxing agent, rinse the vehicle thoroughly with water.

## 2. CLEANING VEHICLES

### 2.1 HIGHPRESSURE CLEANER

It is advisable to clean the vehicle with a highpressure cleaner before starting maintenance or service operations. A clean vehicle makes the mechanic's work easier, and enables him to notice any defects at an early stage.

**Note:**

Before cleaning the vehicle, check the engine, axles, gearbox, etc. for evidence of leakage.

If the vehicle is cleaned with a highpressure cleaner, the latter must be used with care. It is also important to observe the following points:

- Make sure that doors, windows and roof hatch are securely closed during highpressure cleaning.
- When cleaning the universal joint on the steering box, the spider seals may be forced open by the highpressure jet of water, so that the grease behind them is flushed away. As a result, the spider may get stuck, so that the steering mechanism will jam.
- A bleed screw is fitted to the power steering fluid reservoir of the steering system. Water may enter the tank through this, causing damage to the steering mechanism.
- When cleaning the radiator/intercooler, be careful not to damage the fins.
- Do not direct the highpressure cleaner jet too long at the airconditioning system condenser. As a result of the high temperature, the pressure in the system will become excessive, which may cause damage to the system.

- Make sure that no water can enter the differential or the gearbox via the breathers.
- Make sure that no water can enter via the reservoir bleed screws of clutch, brakes, trailing axle, etc.
- The engine and engine compartment can be cleaned with a highpressure cleaner. Make sure in this case not to spray onto electrical components, such as the starting motor, alternator, etc.
- Maintain a minimum distance of 50 cm between the engine encapsulation and the sprayer nozzle to prevent damage to the encapsulation.
- Do not aim the jet of water directly at electrical connections such as connectors, cable plugs of the vehicle lighting system, etc.
- Ensure that no water can enter the air inlet system via the air intake or its flexible seals.
- When the vehicle has been cleaned, it must be lubricated again with a grease gun or via the automatic lubrication system. This is important because it prevents the penetration of moisture and dirt at the various pivot points.



**CONTENTS**

	<b>Page</b>	<b>Date</b>
<b>1. PAINT TREATMENT</b> .....	1-1 .....	0107
1.1 General instructions .....	1-1 .....	0107
1.2 Respraying/paint repairing of cab top coat and SMC polyester parts .....	1-3 .....	0107
1.3 Respraying/paint repairing chassis finishing .....	1-5 .....	0107
1.4 Respraying seed top coats .....	1-6 .....	0107
1.5 Respraying thermoplastic polymer parts .....	1-7 .....	0107
1.6 Respraying glass-fibre reinforced polyester parts .....	1-8 .....	0107



## 1. PAINT TREATMENT

### 1.1 GENERAL INSTRUCTIONS

In the chapter "Paint treatment", directives are provided for respraying and repairing DAF paint systems applied on various subsurfaces. The products to be used are supplied by a range of manufacturers. However, only use products from well-known manufacturers that provide all products for the complete paint structure. The use of these products must be described in the instructions issued by the manufacturer.

Work according to the instructions listed below:

- For rust-removal, use a rust-removal agent based on phosphoric acid.
- To clean and remove any preserving agents, use an organic, chlorine-free solvent.
- Use a two-component epoxy or polyester-based primer.
- Use a two-component epoxy or polyester-based filler.
- Use a two-component epoxy or polyester-based spray filler.
- Use a two-component epoxy or polyester-based filler.
- Use a two-component epoxy PUR finishing coat, with a degree of gloss of more than 92 degrees for cab top coats and a degree of gloss of 70 degrees for chassis finishing (measured at 60 degree geometry).
- Maximum drying temperature is 80 °C, with the exception of fibre-glass strengthened hand lay-up parts. Maximum drying temperature of fibre-glass reinforced hand lay-up parts is 60°C.
- For the paint structure, use only products from the same supplier.
- Use the products according to the manufacturer's instructions.
- Never use products containing silicone in an aerosol can.



**Failure to follow the generally applicable safety rules for using paints and similar products can result in serious injury and/or danger.**

**During work with a rust-removal agent, wear protective gloves and safety goggles.**

**When using paints and similar products, and when handling paint waste, always work according to the applicable environmental requirements, to prevent unnecessary environmental pollution.**

### Colour coding

On the paint identification plate, the DAF code number for the cab paint is listed, up to mid-1996, together with a colour description, for example, DFBRILWIT.

As from mid-1996, the colour code number used by the paint manufacturer "Dupont" is used instead of the colour description. The "Dupont" colour code number consists of five or six characters/digits. The "Dupont" colour code number is followed by the paint colour or an abbreviation.

For example, in the code number L1041MEYL, L1041 is the Dupont colour code number of the paint, ME indicates that it is a metallic paint and YL is the colour abbreviation, in this case yellow. The paint identification plate is mounted on a door pillar on the vehicle.

As from mid-1995, the DAF code number for the cab paint is also marked on the vehicle identity card. For vehicles where the DAF code number is not yet printed on the identity card, a new identity card can be requested from DAF, also bearing the DAF code number for cab paint.

### Removing rust

- Apply the rust-removal agent in accordance with the manufacturer's instructions. The concentration of the rust-removal agent must be adapted to the amount of rust.
- Preferably use a rust-removal paste on vertical parts.
- Prevent rust-removal agents entering overlap joints.

- Leave the rust-removal agent to work, for the time specified by the manufacturer.
- Rinse the area cleaned of rust at least twice with an ample amount of clean tap water.
- Dry the area cleaned of rust.

## 1.2 RESPRAYING/PAINT REPAIRING OF CAB TOP COAT AND SMC POLYESTER PARTS

### Respraying of cab top coat and SMC polyester parts

1. Remove any preserving agents, if applicable; see main group "General Operations".
2. Remove any rust with a rust-removal agent.
3. Clean the area to be sprayed with a solvent.
4. Sand the section to be resprayed with 3M Scotch Brite ultra fine or an equivalent product.
5. Remove any dust from the sanded section with a Tack-rag cloth.
6. Clean the area to be sprayed with a solvent.
7. Apply primer to any bare patches.
8. Leave the primer to evaporate/dry.
9. Apply a filler, if necessary.
10. Leave the filler to evaporate/dry.
11. Fine-sand with 3M Scotch Brite ultra fine or an equivalent product.
12. Remove any dust from the sanded section with a Tack-rag cloth.
13. Clean the area to be sprayed with a solvent.
14. Apply the top coat according to the manufacturer's instructions.
15. Leave the top coat to evaporate/dry. Comply with the drying time as laid down in the manufacturer's instructions.

**Paint repairing of cab top coat and SMC polyester parts**

1. Remove any preserving agents, if applicable; see main group "General Operations".
2. Remove any rust with a rust-removal agent.
3. Clean the area to be repaired with a solvent.
4. Sand the area to be repaired first with P80 sand paper and then with P180 sand paper.
5. Remove any dust from the sanded section with a Tack-rag cloth.
6. Fill the area to be repaired.
7. Sand the filled area with P180 sand paper.
8. Fine-sand/roughen the area to be sprayed with 3M Scotch Brite ultra fine or an equivalent product.
9. Remove any dust from the sanded section with a Tack-rag cloth.
10. Clean the area to be sprayed with a solvent.
11. Apply a primer.
12. Leave the primer to evaporate/dry.
13. Apply a filler.
14. Leave the filler to evaporate/dry.
15. If necessary, fine-sand with 3M Scotch Brite ultra fine or an equivalent product. Following fine-sanding, remove any dust with a Tack-rag cloth and clean the area with a solvent.
16. Apply the top coat according to the manufacturer's instructions.
17. Leave the top coat to evaporate/dry. Comply with the drying time as laid down in the manufacturer's instructions.

### 1.3 RESPRAYING/PAINT REPAIRING CHASSIS FINISHING

1. Remove any preserving agents, if applicable; see main group "General Operations".
2. Remove any rust with a rust-removal agent.
3. Clean the area to be treated with solvent.
4. Sand the area to be treated with P80 sand paper.
5. Remove any dust from the sanded section with a Tack-rag cloth.
6. Clean the area to be treated with solvent.
7. Apply primer to any bare patches.
8. Leave the primer to evaporate/dry.
9. If necessary, sand with P180 sand paper. Following sanding, remove any dust with a Tack-rag cloth and clean the area with a solvent.
10. Apply the top coat according to the manufacturer's instructions.
11. Leave the top coat to evaporate/dry. Comply with the drying time as laid down in the manufacturer's instructions.

**1.4 RESPRAYING SEED TOP COATS**

These instructions relate to parts in steel, SMC (Sheet Moulding Compound) plastic or glass-fibre reinforced polyester.

1. Remove any preserving agents, if applicable; see main group "General Operations".
2. Remove any rust with a rust-removal agent.
3. Clean the area to be sprayed with a solvent.
4. Sand the area to be repaired first with P80 sand paper and then with P180 sand paper.
5. Remove any dust from the sanded section with a Tack-rag cloth.
6. Clean the area to be sprayed with a solvent.
7. In the case of plastic, blow ionised air over the area to be resprayed, or clean the area with an anti-static liquid.
8. Apply the seed top coat according to the manufacturer's instructions.
9. Leave the paint to evaporate.
10. Comply with the drying time as laid down in the manufacturer's instructions.



## 1.5 RESPRAYING THERMOPLASTIC POLYMER PARTS

Thermoplastic polymers include the following "elastic" plastics: ASA, ABS and PUR.

1. Remove any preserving agents, if applicable; see main group "General Operations".
2. Clean the area to be sprayed with a solvent.
3. Sand the area to be resprayed with P180 sand paper
4. Fine-sand with 3M Scotch Brite ultra fine or an equivalent product.
5. Remove any dust from the sanded section with a Tack-rag cloth.
6. Blow ionised air over the area to be resprayed, or clean the area with an anti-static liquid.
7. Clean the area to be sprayed with a solvent.
8. Bring an elastic top coat (10-15% elastifier in the base paint) according to the manufacturer's instructions.
9. Leave the top coat to evaporate/dry. Comply with the drying time as laid down in the manufacturer's instructions.

**1.6 RESPRAYING GLASS-FIBRE REINFORCED POLYESTER PARTS**

These parts can be recognised by the visible fibre-glass structure at the rear of the part, and the gel coating at the front of the part.

1. Remove any preserving agents, if applicable; see main group "General Operations".
2. Clean the area to be sprayed with a solvent.
3. Sand the area to be repaired first with P80 sand paper and then with P180 sand paper.
4. Remove any dust from the sanded section with a Tack-rag cloth.
5. Fill the area to be repaired.
6. Leave the filler to dry.
7. Apply spray filler to the part to be resprayed.
8. Leave the spray filler to dry.
9. Sand the filled area first with P80 sand paper and then with P180 sand paper.
10. Remove any dust from the area to be resprayed with a Tack-rag cloth.
11. Clean the area to be sprayed with a solvent.
12. Again remove any dust from the area to be resprayed with a Tack-rag cloth.
13. Blow ionised air over the area to be resprayed, or clean the area with an anti-static liquid.
14. Apply filler to the area to be resprayed.
15. Leave the filler to evaporate/dry.

16. If necessary, fine-sand with 3M Scotch Brite ultra fine or an equivalent product.
17. Remove any dust from the area to be resprayed with a Tack-rag cloth.
18. Blow ionised air over the area to be resprayed, or clean the area with an anti-static liquid.
19. Apply the top coat according to the manufacturer's instructions.
20. Leave the top coat to evaporate/dry. Drying temperatures must not exceed 60°C. Comply with the drying times listed in the manufacturer's instructions.



CONTENTS

	Page	Date
1. <b>CONVERSION TABLES</b> .....	1-1 .....	0107
Consumption .....	1-1 .....	0107
Specific consumption .....	1-1 .....	0107
Speed .....	1-1 .....	0107
Temperature .....	1-1 .....	0107
Weight .....	1-1 .....	0107
Length .....	1-2 .....	0107
Area .....	1-2 .....	0107
Volume .....	1-2 .....	0107
Pressure .....	1-3 .....	0107
Work .....	1-3 .....	0107
Power .....	1-3 .....	0107



## CONSUMPTION

km/l	1/100 km	miles/gallon (imp)	miles/gallon (US)
n	$\frac{100}{n}$	n x 2.2825	n x 2.352
$\frac{100}{n}$	n	$\frac{282,5}{n}$	$\frac{235,2}{n}$
n x 0.354	$\frac{282,485}{n}$	n	n x 0.83
n x 0.425	$\frac{235,294}{n}$	n x 1.202	n

## SPECIFIC CONSUMPTION

g/kW.h	g/hp.h	g/bh.h	lb/bh.h
1	0.7353	0.7455	0.00164
1.36	1	1.014	0.00224
1.341	0.9863	1	0.00220
608.45	447.4	453.6	1

## SPEED

cm/sec.	m/sec.	km/h	feet/sec	mile/h.
1	0.01	0.036	0.03281	0.02237
100	1	3.6	3.281	2.237
27.78	0.2778	1	0.9113	0.6214
30.48	0.3048	1.097	1	0.6818
44.70	0.4470	1.609	1.467	1

## TEMPERATURE

n° Celsius	=	$\frac{9}{5} n + 32^\circ\text{F} = \frac{4}{5} n^\circ\text{R} = n + 273.15\text{ K}$
n° Fahrenheit	=	$\frac{5}{9} (n - 32)^\circ\text{C} = \frac{4}{9} (n - 32)^\circ\text{R} = \frac{5}{9} (n - 32) + 273.15\text{ K}$
n° Réaumur	=	$\frac{5}{4} n^\circ\text{C} = \frac{9}{4} n + 32^\circ\text{F} = \frac{5}{4} n + 273.15\text{ K}$
n° Kelvin	=	$n - 273.15^\circ\text{C} = \frac{9}{5} (n - 273.15) + 32^\circ\text{F} = \frac{4}{5} (n - 273.15)^\circ\text{R}$

## WEIGHT

kg	ounces	pounds (lbs)	short tons *	long tons *	ton (metr.)
1	35.27	2.205	0.001102	0.0009842	0.001
0.02835	1	0.0625	0.00003125	0.0000279	0.00002835
0.4536	16	1	0.0005	0.0004464	0.0004536
907.2	32000	2000	1	0.8929	0.9072
1016	35840	2240	1.12	1	1.016
1000	35274	2205	1.102	0.9842	1

\* US + UK

# CONVERSION TABLES

0

Conversion tables

95XF series

## LENGTH

mm	inches	feet	yards	m	km	mile (stat.)
1	0.03937	0.003281	0.001094	0.001	0.000001	0.0000006214
25.4	1	0.08333	0.2777	0.0254	0.0000254	0.00001577
304.8	12	1	0.3333	0.3048	0.0003048	0.0001894
914.4	36	3	1	0.9144	0.0009144	0.0005682
1000	39.37	3.281	1.0936	1	0.001	0.0006214
1000000	39370	3281	1093.6	1000	1	0.6214
1609350	63360	5280	1760	1609	1.609	1

## AREA

mm <sup>2</sup>	cm <sup>2</sup>	square inches	square feet	square yards	m <sup>2</sup>
1	0.01	0.00155	0.00001076	0.000001196	0.000001
100	1	0.155	0.001076	0.0001196	0.0001
645.2	6.452	1	0.006944	0.0007716	0.0006452
92900	929	144	1	0.1111	0.09290
836100	8361	1296	9	1	0.8361
1000000	10000	1550	10.76	1.196	1

## VOLUME

cm <sup>3</sup>	US				dm <sup>3</sup> (litre)
	cubic inches	pints	quarts	gallons *	
1	0.06102	0.002114	0.001057	0.0002642	0.001
16.39	1	0.03464	0.01732	0.004329	0.01639
473.2	28.874664	1	0.5	0.125	0.4732
946.4	57.75	2	1	0.25	0.9464
3785	231	8	4	1	3.785
1000	61.02	2.114	1.057	0.2642	1

\* US Gallon = 0.8327 Imp. Gallons

cm <sup>3</sup>	US				dm <sup>3</sup> (litre)
	cubic inches	pints	quarts	gallons **	
1	0.0610248	0.0017598	0.008799	0.000219975	0.001
16.387	1	0.02894	0.01447	0.003618	0.016387
568.2	34.67429136	1	0.5	0.125	0.5682
1136.49	69.319	2	1	0.25	1.13649
4545.95	277.274	8	4	1	4.54596
1000	61.0248	1.7598	0.8799	0.219975	1

\*\* Imp. Gallon = 1.201 US Gallons

7



## PRESSURE

Pa	bar	kg/cm <sup>2</sup>	lbs/sq inch (p.s.i.)	atm
1	0.00001	0.0000101	0.000145	0.0000987
100000	1	1.0197162	14.500364	0.9868813
98066.5	0.980665	1	14.22	0.9678
6894.76	0.0689476	0.070307	1	0.068046
101322.3	1.013223	1.0332	14.70	1
133.32	0.0013332	0.0013595	0.01934	0.0013158
3386.23	0.0338623	0.03453	0.4912	0.3342
9797.82	0.0979782	0.09991	1.421	0.09668
248.89	0.0024889	0.002538	0.03609	0.002456

Pa	column of mercury at 15 °C and g = 980.665 cm/sec <sup>2</sup>		column of water at 15 °C and g = 980.665 cm/sec <sup>2</sup>	
	mm	inches	m	inches
1	0.0075007	0.0002953	0.0001021	0.0040187
100000	750.06708	29.530981	10.207359	401.87015
98066.5	735.56454	28.96	10.01	0.9678
6894.76	51.715	2.036	0.7037	0.068046
101322.3	760	29.92	10.337	1
133.32	1	0.03937	0.01361	0.0013158
3386.23	25.40	1	0.3456	0.3342
9797.82	73.49	2.893	1	0.09668
248.89	1.867	0.07349	0.02540	0.002456

## WORK

Nm	mkg	ft.lbs.	kWh	pkh (metr.)	Hph	kcal
1	0.1019716	0.7375607	0.0000002776	0.0000003776	0.0000003725	0.000238882
9.80665	1	7.233	0.000002723	0.0000037037	0.000003653	0.002342
1.356259695	0.1383	1	0.0000003765	0.00000051206	0.00000050505	0.0003238
3601001.88	367200	2656000	1	1.3599	1.341	860
2647795.5	270000	1952900	0.7353	1	0.9863	632.4
2684570.4375	273750	1980000	0.7455	1.0139	1	641.1
4187.43955	427	3088	0.001163	0.001581	0.00156	1

## POWER

kW	hp (metr.)	mkg/sec	kcal/sec	HP	lbs/sec
1	1.36	102	0.2389	1.341	737.7
0.7353	1	75	0.1757	0.9863	542.5
0.009804	0.01333	1	0.002342	0.01315	7.233
4.186	5.693	427	1	5.615	3088
0.7455	1.014	76.04	0.1781	1	550
0.001355	0.00184	0.1383	0.0003238	0.00182	1

